

► Wear plate (PWP - CI)

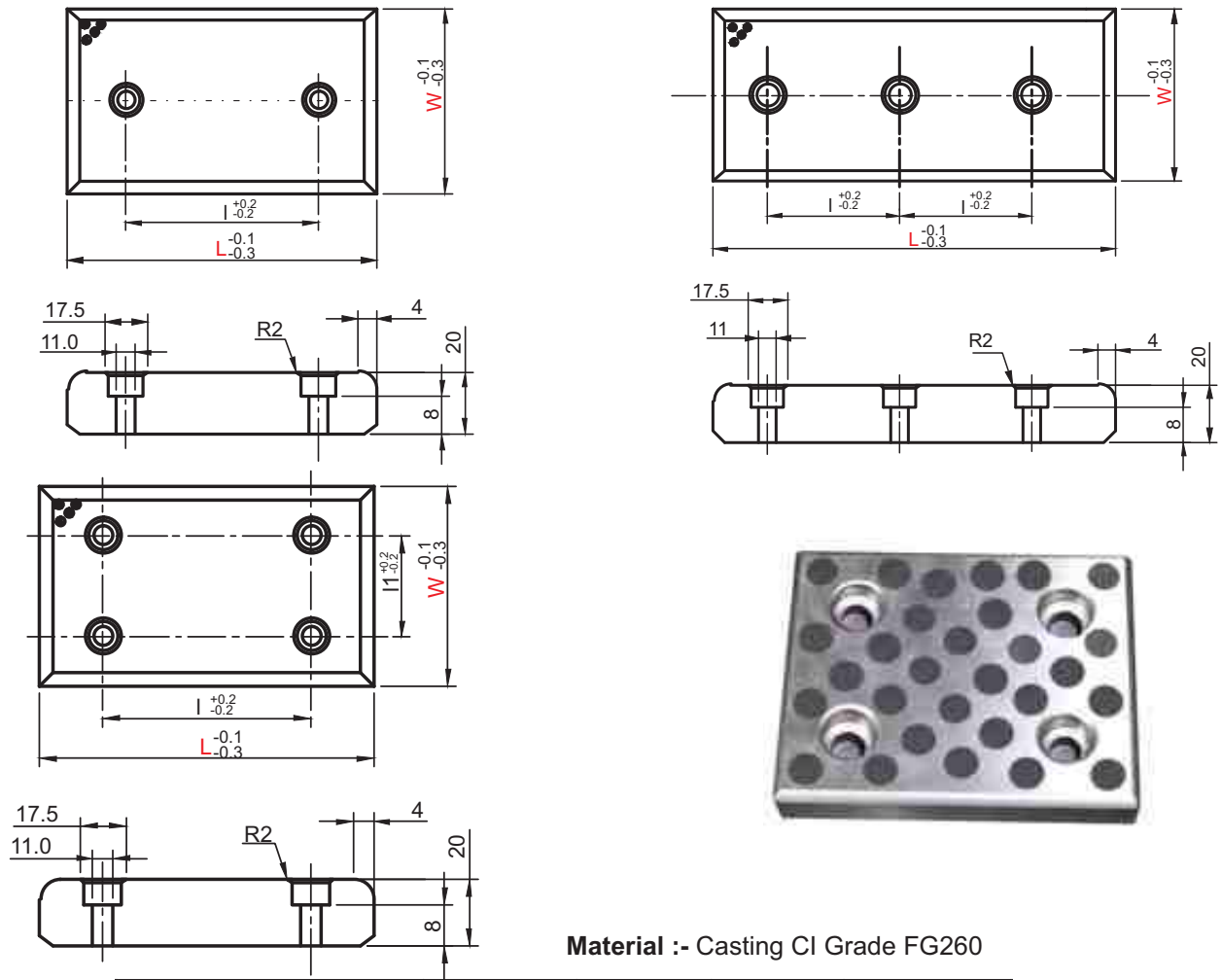

Material :- Casting CI Grade FG260

Type		W	I	I1	L
PWP-CI	4 bolt holes	100	50	50	100
			75		125
			100		150
			150		200
			200		250
		125	75	50	125
			100		150
			150		200
			200		250
			200		300
		150	100	100	150
			150		200
			200		250
			250		300
		200	150	150	200
200	250				
250	300				

Order Type :- Code X W X L | **Example :-** PWP-CI X 100 X 150

► Wear plate (PWP - CI)

Type		W	I	L
PWP - CI	2 bolt holes (W=28 - 75) (*3 bolt holes)	28	45	75
			50	100
			75	125
			100	150
			150	200
		38	45	75
			50	100
			75	125
			100	150
			150	200
		48	45	75
			50	100
			75	125
			100	150
			150	200
	58	45	75	
		50	100	
		75	125	
		100	150	
	75	25	75	
		50	100	
		75	125	
		100	150	
		150	200	
		200	250	
		100*	300	
	2 bolt holes (W=100 - 150)	100	50	100
			75	125
			100	150
			150	200
			200	250
			200	300
		125	75	125
			100	150
			150	200
			200	250
200			300	
150	100	150		
	150	200		
	200	250		
	250	300		

Order Type :- Code X W X L
Example :- PWP-CI X 100 X 150